

NUMBER: SB 500-57-013, Rev A
MODEL: ECLIPSE EA500
SUBJECT: Wing Corrosion Inspection

Recommended

www.eclipse.aero

1. PLANNING INFORMATION

A. Effectivity

Aircraft Serial Numbers: 000001-000262, 000266-000267

B. Reason

Corrosion has been found on the underside of wings on fielded aircraft.

C. Description

This Service Bulletin provides instructions to inspect the undersides of wings for corrosion.

D. Compliance

Eclipse Aerospace Inc. considers this to be a recommended inspection that should be accomplished at the next maintenance visit.

E. Approval

This Service Bulletin is based on engineering data that is FAA-approved, and the modification herein complies with the applicable regulations.

F. Labor Requirements

The following information is for planning purposes only.

(1) Estimated labor hours to perform:

Suggested number of personnel: 1

Estimated in service days: 1

Total labor hours: 4

The above is an estimate based on properly equipped and experienced personnel complying with this Service Bulletin. Actual labor hours may vary depending on workforce experience, concurrent maintenance, discovery of other discrepancies, etc.

(2) Qualification of personnel:

- A person properly authorized under 14 CFR 43 to perform aircraft maintenance.

G. Weight and Balance Change

N/A

H. Electrical Load Data Change

N/A

I. Software Accomplishment Summary

N/A

J. References

- 06-117751, EA500 AMM, current revision
- 06-117755, EA500/EA550 Structural Repair Manual
- SB 500-57-008 - Flap Actuator Upgrade

K. Publications Affected

None.

2. MATERIAL INFORMATION

A. Materials

None

B. Interchangeability/Intermixability of Parts

N/A

C. Part Re-identification

None

D. Consumables

The following consumables are required for this Service Bulletin.

Material	Specification	Use
Sealant	PRC-Desoto PR-2001 or equivalent ^[1]	Fairing fay and fillet sealing
Corrosion Preventive Lubricant ZIP-Chem	D-5026NS or equivalent to MILPRF-81309, Type II, class 1 or 2	Corrosion Preventive

[1] Permissible to use RTV-162.

E. Tooling

Description	Qty	Unit of Issue
Flashlight	1	EA.
Inspection Mirror	1	EA.

F. Cost

Contact Eclipse Aerospace Customer Care (customer.service@eclipse.aero, phone: (505) 724-1784) for information and availability.

3. ACCOMPLISHMENT INSTRUCTIONS

A. Job Set-up

- (1) Make the aircraft safe for maintenance. Refer to AMM 20-00-01 -- MAKE SAFE FOR MAINTENANCE.
- (2) Connect external electrical power. Refer to AMM-24-40-00-051-801 – External Power - Maintenance Practices.
- (3) Move the flap position lever to the LDG position and extend the flaps.
- (4) Remove external power from the aircraft. Refer to AMM-24-40-00-051-801 – External Power - Maintenance Practices.
- (5) Remove the fairings that follow:

NOTE: Illustrations are shown for the left wing and the right wing are opposite and the same.

(a) Aircraft PRE SB 500-57-008, LH and RH Outboard Flap Track Fairings, Aft:

1. Remove Outboard Flap Track Fairing, Aft, (LH) (1, [Figure 1](#)) and (RH) by removing four Screws – P/N NAS8702-2 (5, [Figure 1](#)).

(b) Aircraft post SB 500-57-008, LH and RH Outboard Flap Track Fairings, Aft:

1. Remove Outboard Flap Track Fairings, Aft (LH) (1, [Figure 1](#)) and (RH) by removing four Screws – P/N NAS8702-2 (5, [Figure 1](#)).

(c) Aircraft post SB 500-57-008, LH and RH Outboard Flap Track Fairings, Forward:

1. Remove Outboard Flap Track Fairing, Forward (LH) (2, [Figure 1](#)) and (RH) by removing Screws – P/N NAS7702-2 (3, [Figure 1](#)), P/N NAS7702-3 (4, [Figure 1](#)) and two P/N NAS8702-2 (5, [Figure 1](#)).

(d) LH and RH Mid Flap Track Fairings, Aft:

1. Remove Mid Flap Track Fairing, Aft (LH) (6, [Figure 1](#)) and (RH) by removing four Screws – P/N NAS8702-2 (5, [Figure 1](#)).

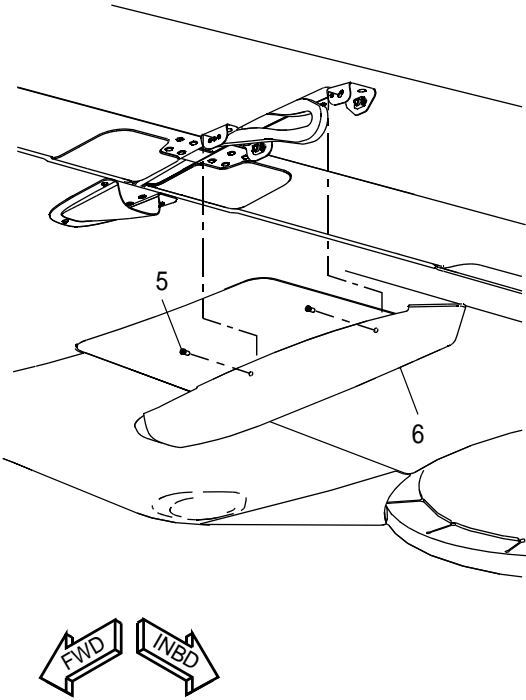
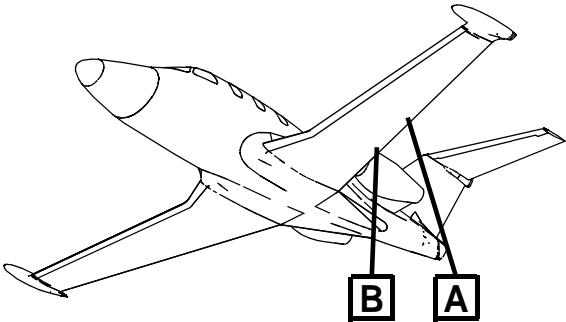

B
MID

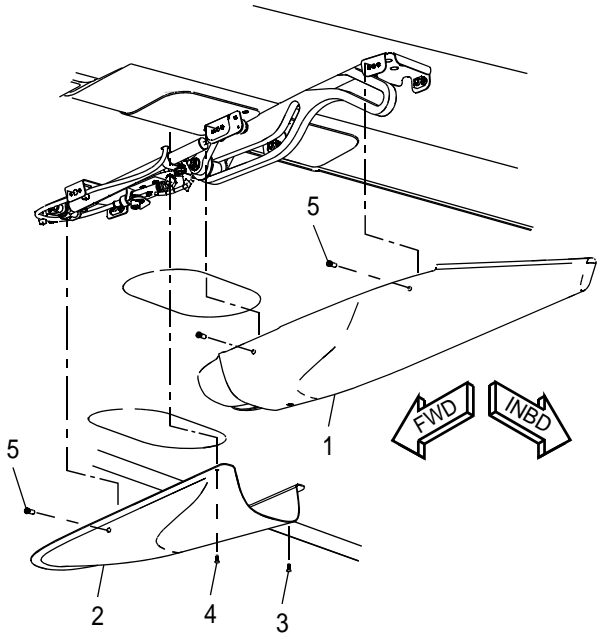

A
OUTBOARD

5202048A

Figure 1. Mid and Outboard Flap Track Removal

B. Inspection

Inspect both the left and right wings as follows:

Refer to [Figure 2](#) and [Figure 3](#).

Examples of damage are shown on [Figure 4](#), [Figure 5](#), [Figure 6](#) and [Figure 7](#).

- (1) Aircraft PRE SB 500-57-008; with a flashlight and mirror, inspect the area inside the Outboard Flap Track Fairing, Forward for corrosion. Inspect the outside perimeter of the Outboard Flap Track Fairing, Forward where it attaches to the wing for corrosion.
- (2) Aircraft post SB 500-57-008; inspect the area where the Outboard Flap Track Fairings, Forward and Aft attaches to the wing and flap for corrosion.
- (3) With a flashlight and mirror, inspect the area inside the Mid Flap Track Fairing, Forward for corrosion. Inspect the outside perimeter of the Mid Flap Track Fairing, Forward where it attaches to the wing for corrosion.
- (4) Inspect the area on the flap where the Mid Flap Track Fairing, Aft attaches to the flap for corrosion.
- (5) Inspect the Landing Gear Bay for corrosion:
 - (a) Lower wing skins at the root rib.
 - (b) Lower skins at the main spar
 - (c) Lower wings skins at MLG Door lands
 - (d) Lower Skin at the MLG Door Hinge.
 - (e) Lower Skins at the Fuel Drains
- (6) If corrosion is found, provide photographs and provide details on the Structural Damage Report and Repair Request. Refer to [Figure 8](#). Send documentation to Eclipse Aerospace Service Engineering for evaluation. Refer to "NOTIFYING ECLIPSE AEROSPACE" on page 12.
- (7) Apply Corrosion Preventive Lubricant ZIP-Chem D-5026NS or equivalent to MILPRF-81309, Type II, class 1 or 2 to the subject areas per AMM 20-10-00, SUBTASK AMM-20-10-00-051-911-006.

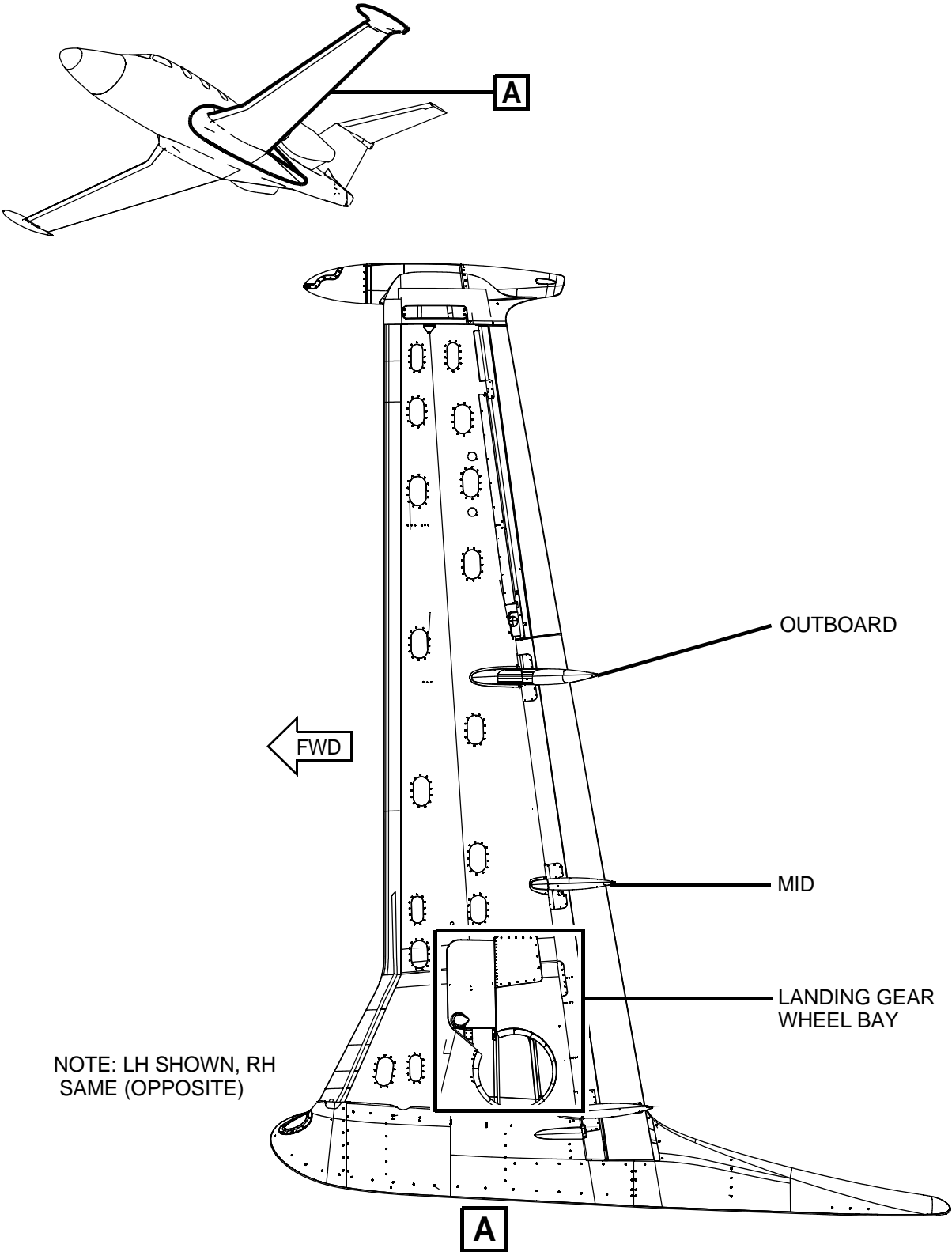

Figure 2. Wing Corrosion Inspection

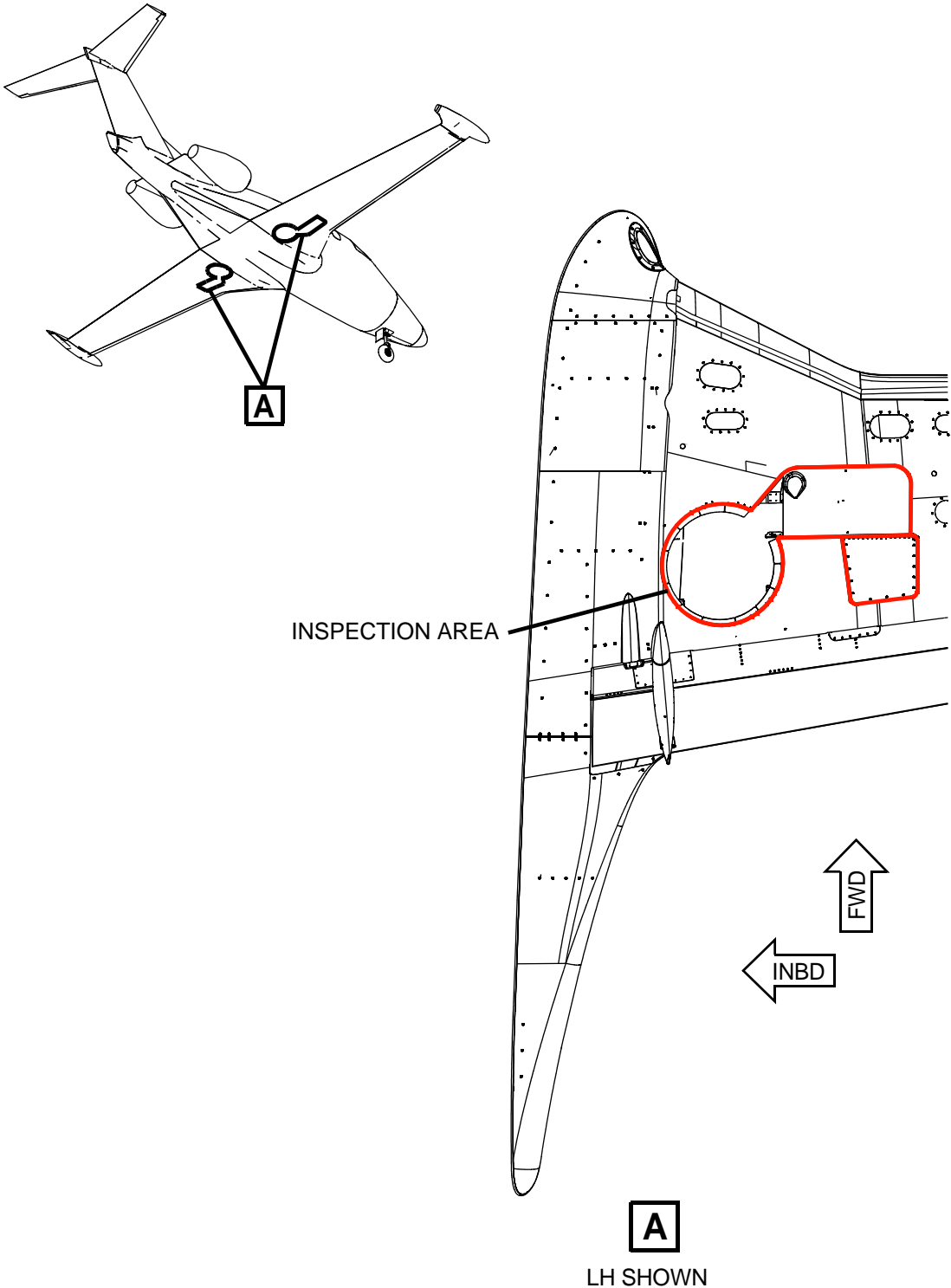

Figure 3. Inspection - MLG Wheel Bay

5202050A



Figure 4. Example of Damage - Outboard Forward Flap Track Fairing



Figure 5. Example of Damage - Outboard Forward Flap Track Fairing



Figure 6. Example of Damage - Mid Forward Flap Track Fairing



Figure 7. Example of Damage - Wing Skin at Landing Gear Door

STRUCTURAL DAMAGE REPORT AND REPAIR REQUEST

Today's Date: _____

Contact Name: _____

Phone: _____

Fax: _____

e-mail: _____

Aircraft Model: _____ S/N: _____ Registration No.: _____

T.T.: _____ Flight Cycles: _____ Aircraft Location: _____

Maintenance Status: _____
eg; Scheduled Inspection (Indicate No.), Unscheduled AOG.

Which major assemblies have been damaged? Check all that apply, circle Left or Right, and list affected part number(s).

<u>Component Assembly</u>	<u>A/C Side</u>	<u>Part Number</u>
<input type="checkbox"/> Powerplant Structure ATA 71	Left or Right	_____
<input type="checkbox"/> Pylon	Left or Right	_____
<input type="checkbox"/> Main Landing Gear	Left or Right	_____
<input type="checkbox"/> Nose Landing Gear		_____
<input type="checkbox"/> Wing		_____
<input type="checkbox"/> Vertical Fin or Rudder		_____
<input type="checkbox"/> Fuselage		_____
<input type="checkbox"/> Wing Panel or Control Surface	Left or Right	_____
<input type="checkbox"/> Horizontal Stabilizer or Elevator	Left or Right	_____

If the damaged component(s) is (are) life limited, provide the following:

Component S/N: _____

Component Landings/Cycles/Hours: _____

5S51051530SBA

Figure 8. Structural Damage Report and Repair Request

C. Job Close-up

- (1) Install the access panels that follow:
 - (a) Aircraft PRE SB 500-57-008, LH and RH Outboard Flap Track Fairings, Aft:
 1. Install Outboard Flap Track Fairing, Aft, (LH) (1, [Figure 1](#)) and (RH) with four Screws – P/N NAS8702-2 (5, [Figure 1](#)).
 2. Fay seal points of contact on fairing with PR-2001.
 3. Fillet seal Outboard Flap Track Fairings, Aft with PRC-Desoto Sealant (PR-2001).
 - (b) Aircraft post SB 500-57-008, LH and RH Outboard Flap Track Fairings, Aft:
 1. Install Outboard Flap Track Fairings, Aft (LH) (1, [Figure 1](#)) and (RH) with four Screws – P/N NAS8702-2 (5, [Figure 1](#)).
 2. Fay seal points of contact on fairing with PR-2001.
 3. Fillet seal Outboard Flap Track Fairings, Aft with PRC-Desoto Sealant (PR-2001).
 - (c) Aircraft post SB 500-57-008, LH and RH Outboard Flap Track Fairings, Forward:
 1. Install Outboard Flap Track Fairing, Forward (LH) (2, [Figure 1](#)) and (RH) with Screws – P/N NAS7702-2 (3, [Figure 1](#)), P/N NAS7702-3 (4, [Figure 1](#)) and two P/N NAS8702-2 (5, [Figure 1](#)).
 2. Fay seal points of contact on fairing with PR-2001.
 3. Fillet seal Outboard Flap Track Fairings, Forward with PRC-Desoto Sealant (PR-2001).
 - (d) LH and RH Mid Flap Track Fairings, Aft:
 1. Mid Flap Track Fairing, Aft (LH) (6, [Figure 1](#)) and (RH) with four Screws – P/N NAS8702-2 (5, [Figure 1](#)).
 2. Fay seal points of contact on fairing with PR-2001.
 3. Fillet seal Mid Flap Track Fairings, Aft with PRC-Desoto Sealant (PR-2001).
- (2) Allow sealant to cure.
- (3) Connect external electrical power. Refer to AMM-24-40-00-051-801 – External Power - Maintenance Practices.
- (4) Move the flap position lever to the UP position and retract the flaps.
- (5) Remove external power from the aircraft. Refer to AMM-24-40-00-051-801 – External Power - Maintenance Practices.
- (6) Remove all tools, equipment and unwanted material from the work area.
- (7) If all other maintenance is complete, return the aircraft to service. Refer to the AMM 20-00-02 RETURN TO SERVICE (AFTER MAINTENANCE).

D. Limitations and Procedures

N/A

E. Parts Disposition

N/A

4. RECORD OF COMPLIANCE

Upon completion of this Service Bulletin, make an appropriate maintenance-record entry specifying the Service Bulletin number.

5. NOTIFYING ECLIPSE AEROSPACE

On completing this Service Bulletin, the operator/maintainer shall complete the attached Compliance Record and send it to Eclipse Aerospace via regular mail, fax, or e-mail.

Mailing Address	Eclipse Aerospace Incorporated ATTN: Service Engineering 3520 Spirit Drive SE Albuquerque, NM 87106
Fax	1-505-241-8802
E-mail	sbcompliance@eclipse.aero

[Intentionally Blank Page]

